

CITY CRANE MC 60

LHW2

POTAIN  [®]

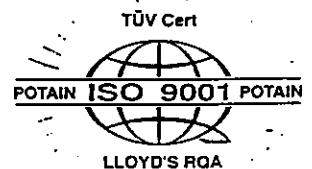

Mats - Maste - Masts - Mástil - Torre



□ 1,2m

Flèche - Ausleger - Jib
Flecha - Braccio
30m → 43m

P 12A

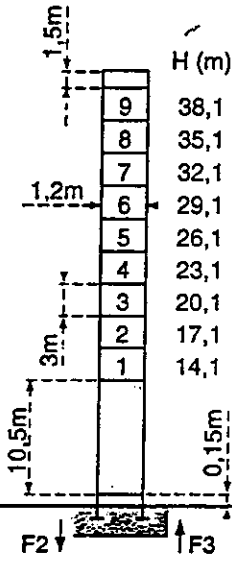

F2	● 57t	■ 83t
F3	● 43t	■ 70t
⊕	19,5t	

P 12A

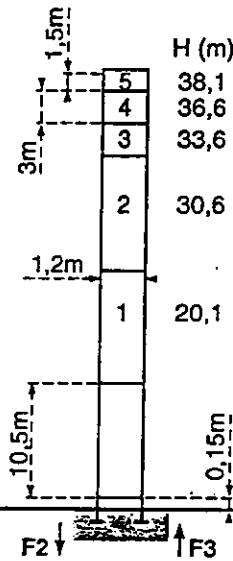

F2	● 57t	■ 83t
F3	● 43t	■ 70t
⊕	19,5t	

B 125A

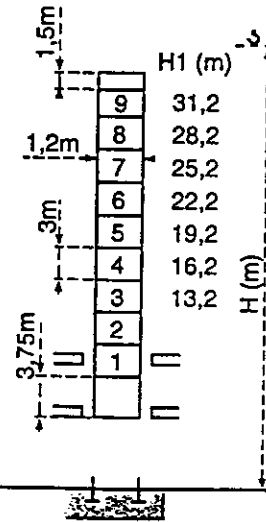

Voir ci-contre
Siehe nebenstehend
See opposite
Ver pagina opuesta
Vedi pagina accanto

ZE 12A

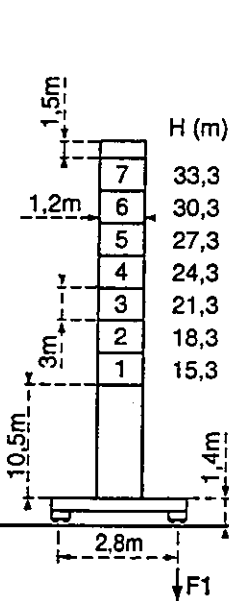

F1	● 40t	■ 49t
⊕	22,5t	

ZF 12A

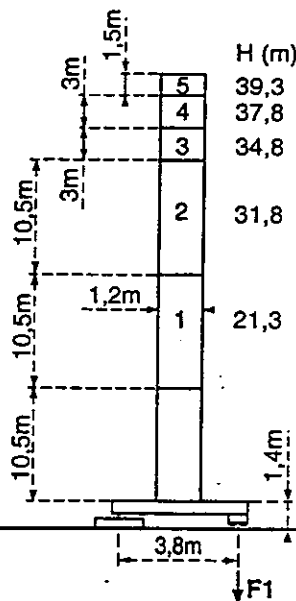

F1	● 38t	■ 51t
⊕	24,5t	

ZF 12A

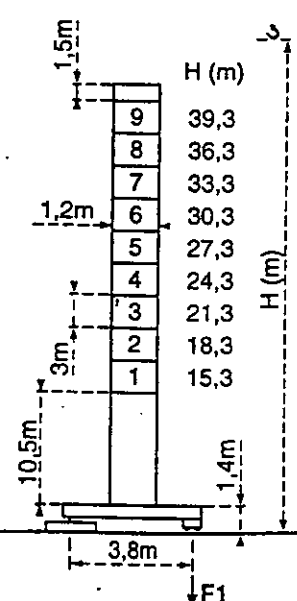



F1	● 38t	■ 51t
⊕	24,5t	

F = Réactions - Eckdrücke - Reactions - Reacciones - Reazioni

Courbes de charges - Lastkurven - Load diagrams - Curvas de cargas - Curve di carico

 Flèche Ausleger Jib Flecha Braccio

43 m 	19,9	22	25	27	30	32	35	37	40	41	43	m
	2,5	2,22	1,9	1,73	1,52	1,4	1,25	1,16	1,04	1,01	0,95	t

40 m 	20,6	22	25	27	30	32	35	37	40	m
	2,5	2,31	1,98	1,81	1,59	1,46	1,31	1,21	1,1	t

30 m 	22,7	25	27	30	m
	2,5	2,24	2,04	1,8	t

ZE

ZF

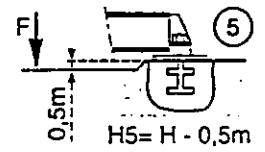
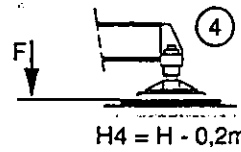
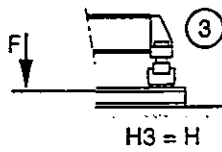
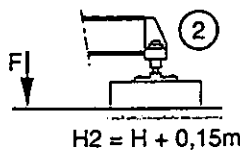
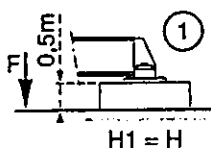

Télescopage sur dalles - Kletterkrane im Gebäude - Climbing crane Telescopage gruas trepadoras - Gru in cavedio

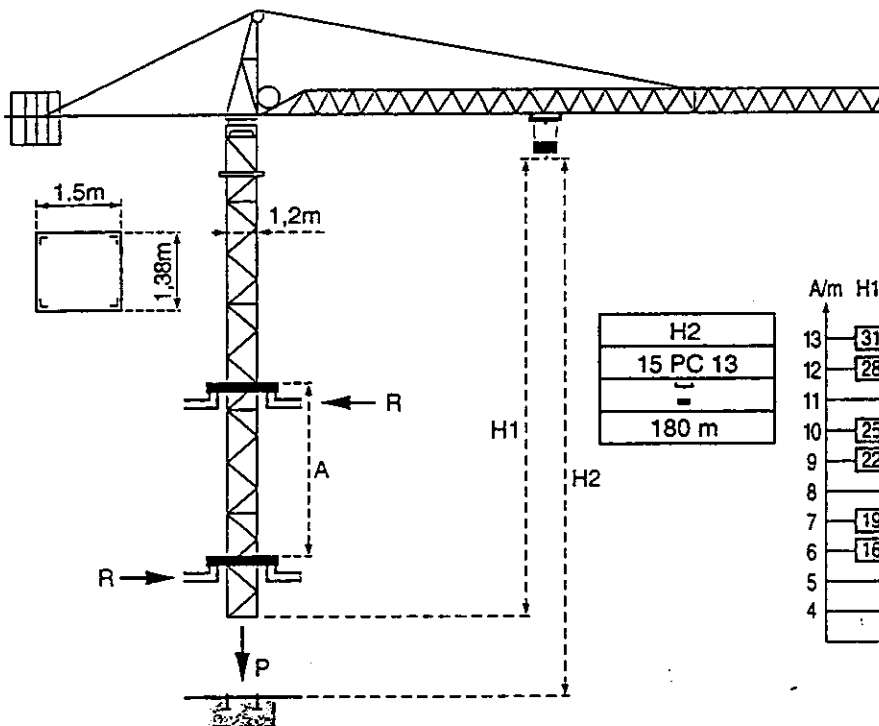

B 125A

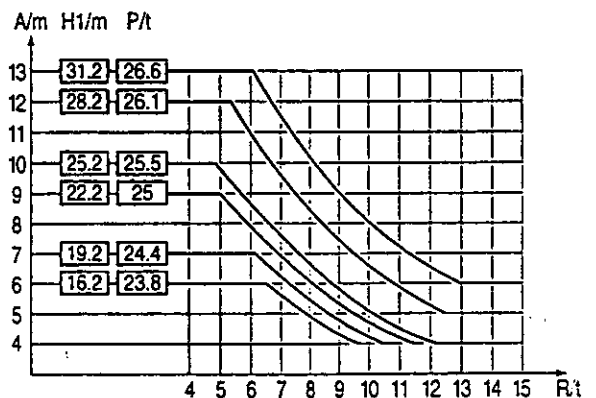

A Distance entre cadres

H1 Hauteur grue

P Poids de la grue (en service)

R Réaction horizontale

A Abstand zwischen den Rahmen

H1 Kranhöhe

P Krangewicht (in Betrieb)

R Horizontalkräfte

A Distance between collars

H1 Crane height

P Crane weight (in service)

R Horizontal reaction

A Distancia entre marcos

H1 Altura grúa

P Peso de la grúa (en servicio)

R Reaccion horizontal

A Distanza fra i telai

H1 Altezza gru

P Peso della gru (in servizio)

R Reazione orizzontale

● En service

■ Hors service

● In Betrieb

■ Ausser Betrieb

● In service

■ Out of service

● En servicio

■ Fuera de servicio

● In servizio

■ Fuori servizio

⊗ A vide sans lest avec flèche et hauteur maximum.

⊗ Ohne Last und Ballast mit Maximalausleger und Maximalhöhe.



















⊗ Without load and ballast with longest jib and maximum height.

⊗ Sin carga, sin lastre con flecha y altura máxima.

⊗ A vuoto senza zavorra e con braccio massimo e altezza massima.

POTAIN  CITY CRANE MC 60

Mécanismes - Antriebe - Mechanisms - Mecanismos - Meccanismi

				m/min	t		ch -PS hp	kW
Levage Heben Hoisting Elevación Sollevamento	15 PC 13   			7	2,5	360 m	15	11
				21	2,5			
				42	1,3			
	25 PC 13   			6	2,5	360 m	25	18,4
				35	2,5			
				70	1,3			
Distribution - <i>Katzfahren</i> - Trolleying Distribución - Distribuzione		3 D2 V5	21 - 42			3	2,2	
Orientation - <i>Schwenken</i> - Slewing Orientación - Rotazione		RCV 40	0 → 0,8 tr/min U/min-rpm			6	4,5	
Translation - <i>Kranfahren</i> - Travelling Traslación - Traslazione	ZE - ZF 	TVD 324 C1	26			2 x 4	2 x 2,9	
Réseau - <i>Netzstrom</i> - Mains supply - Red - Rete elettrica						CEI 38 IEC 38	400V (+6%, -10%) 50Hz	
Puissance électrique nécessaire - <i>Anschlusswert</i> - Necessary electric power Potencia eléctrica necesaria - <i>Potenza elettrica necessaria</i>							15 PC : 25 KVA 25 PC : 35 KVA	
Groupe électrogène - <i>Stromaggregat</i> - Generator set - <i>Grupo electrogeno</i> - Gruppo elettrogeno							.	

*Nous consulter - Auf Anfrage - Consult us - Consultarnos - Consultateci

Conforme aux directives CEE 84/534 et 87/405 sur le niveau acoustique - Gemäss EWG-Richtlinien 84/534 und 87/405 für den Schall- Leistungspegel
 In compliance with the EEC 84/534 and 87/405 instructions on noise level - Conforme con las directivas CEE 84/534 y 87/405 sobre el nivel acustico
 Conforme alle direttive CEE 84/534 e 87/405 sul livello acustico



Copyright.Reproduction interdite © POTAIN 1994

POTAIN 

GRUPE LEGRIS INDUSTRIES

18.Rue de Charbonnières. B.P. 173-F 69132 ECULLY Cedex
 Tél. (33)04.72.20.20.20 - Fax (33)04.72.20.20.00

POTAIN GmbH	Deutschland	Tel : 06.105.704.0
POTAIN U.K.	Great Britain	Tel : 0895.44.52.61
Simna POTAIN	Italia	Tel : 02.97.96.71
POTAIN Portugal	Portugal	Tel : 02.968.08.89
POTAIN Belgium	Belgique	Tel : 15.42.08.80
Zhangjiagang POTAIN	China	Tel : 520. 877.451

CITY CRANE MC 60

Réf. 1994.29 LHW 3

Modifiche riservate

Modificaciones reservadas

Subject to modification

Änderungen vorbehalten

Modificacions reservades

Printed in France

Modificación SODIP/E